

**Come home to Nectre**



**NECTRE**

**SLOW COMBUSTION HEATING**

Built so you won't get burnt..... 2  
 Combustion heating..... 3  
 How to get the best from your Nectre..... 6  
 The compliance factor..... 8  
 Hot topics..... 9  
 Great baking recipes..... 10

**Nectre MkII** gives you a warm feeling inside



**Built so you won't get burnt.**

Knowing what's hot in wood heaters can be difficult. Let's face it, most wood heaters are similar. But ask yourself the following when making comparisons to a Nectre. Has the heater been tested to conform to Australian standards for clearance and emissions? Are all joints MIG welded? Are all the walls of the heater box lined with firebricks? Can I load really large logs and then watch them burn through huge ceramic glass windows? Does it have a cast iron door with heat proof woven rope providing an airtight seal plus specially designed air control and door handles that not only look good but are simple to use and stay cool? We're biased, but we reckon your decision will be easy.



Nectre MkII Legs



Nectre MkII Pedestal

What can make you feel warmer than curling up with a good book or perhaps a cuddly friend, by a roaring living fire.

A Nectre fire is an integral part of any gathering, unlike some forms of heating that provide a sterile heat. Your Nectre fire has character as well as warmth. Ever noticed how people will back up to their Nectre even when the room is obviously warm? It's not only to draw in as much of that lovely deep radiant warmth as possible, but also to interact with the living fire.

**The case for double casing.**

MkII has the same simple but elegant lines of all Nectres but is double cased so it can be installed very close to walls or furniture.

The double casing also maximises air convection and shifts heated air around your home with great effectiveness. An average output of 21kW (75,000btu) makes the MkII the perfect heater for homes that are hard to heat and where installation is tight. You and your family will live in comfort for years to come.



**Nectre MkI**

**the original Nectre**

**The simple story of combustion heating.**

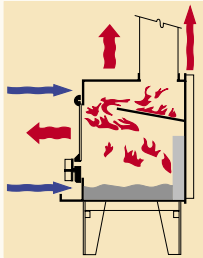

Simplicity is why Nectre is the first choice in wood heaters. Primary air enters the firebox through the door and is directed at the heart of the fire, creating a turbulent mix of combustible gases.

Another inlet located at the top of the door allows a carefully measured amount of additional air to enter, completing secondary combustion of unburnt gases. The result is extremely efficient combustion with high temperatures that are maintained by the firebrick lining and a flue baffle to lengthen the flame path.



Nectre MkI Legs



**Nectre Inbuilt.**

The perfect Nectre for a home with an existing fireplace. It produces 16kW (56,000 btu) – that's around 250% more heat than an open fire. And it uses loads less wood. The fire box maximises convected warm air, and circulates it through your whole home. Ideal for homes of around 15 squares (140 square metres).



Nectre Inbuilt



Nectre MkI Pedestal



### How to get the best out of your Nectre.

Your Nectre has been designed to extract every bit of energy out of every piece of wood. But even a Nectre needs a little help to work at its best, all the time. Here are some hints that will also help the environment.

- Only burn dry seasoned wood. Freshly cut wood is 50% water and when you burn it you also boil it, wasting energy.
- Stack your wood under cover in a well-ventilated area. Newly cut wood should be stored for 8 months before burning.
- Use smaller logs so that plenty of air circulates around the heart of the fire.
- A space above the fire will allow a flame to develop that will burn off the gases released by the wood.
- Burn the fire brightly. Smoke just pollutes the atmosphere and causes creosote to build in the flue, reducing effectiveness of your Nectre.
- If burning overnight, have a flame burning. Run your Nectre at full burn for 15 minutes before turning the heater down for the night.



The Mega Legs

Nothing challenges a wood heater like modern open plan living. But it's hardly a challenge for our newest heater, aptly named, Mega. We designed the Mega with modern living in mind. It produces a whopping 35kW (120,000 btu) of heat making it Australia's most powerful freestanding heater capable of turning 40 squares of open space into a warm, comfortable living area.

The Mega's output make it an ideal heater for large homes or for commercial applications. It will make any ski lodge or sporting club a comfortable place to relax in, however inclement the weather.

Powerful yes, but the Mega is certainly no brute when it comes to looks. The contoured door gives the Mega a soft appearance and opens wide to accept large logs. You can even harness some of the Mega's power to heat your water system by fitting the optional water jacket.



The Mega Pedestal



**Nectre 15**

**compact yet powerful**



### **The compliance factor.**

Air quality is important to all of us and Australia is truly a lucky country when it comes to the air we breathe. Therefore, in the 1990's, an Australian Standard for emissions was established for slow combustion wood fires.

Originally the standard was set at 5.5 grams of particulate emissions per kilogram of wood burnt. This meant that over the high, low and medium burn cycle of a slow combustion wood fire, the average allowable amount of particulate matter (smoke) emitted was 5.5 grams for every kilogram of wood burnt. As you can imagine, 5.5 grams is a very small amount, but in the year 2000 the Australian Home Heating Association, in conjunction with Wood Fire manufacturers and importers, decided they could do better and the maximum amount of particulate matter emitted was reduced to 4.0 grams per kilogram of wood. Over a 25% reduction!

In all instances Nectre wood fires comply with this Australian Standard (AS/NZS 4013). It is important when you are operating your Nectre wood fire that you follow the operating instructions. Always burn a dry, well seasoned hardwood and maintain a brisk burning fire with plenty of flame. Check the flue on the outside of your home. If you see no more than a slight heat haze coming from the flue, you are doing everything correct. You will not only be doing the right thing for our air quality generally, your neighbours will be happy because they won't receive any annoying smoke.

The objective of these standards is to reduce the amount of particulate matter made by wood fires. In doing so the burn time of many fires has been reduced and you can no longer have the long slow slumbering fire that was common in the early 80's. These slumbering fires burnt so low that they did not provide much useable heat but were the cause of some heated disputes between neighbours. By burning your fire as recommended, the output is much higher, the combustion is more efficient and you burn less wood and save money as well as valuable wood fuel resources.

You can sit back and relax knowing your Nectre complies with all Australian standards, and you are doing your bit for air quality.

You'll love the warmth and style of this powerful but compact little heater. The Nectre 15 produces a remarkable 12kW (45,000 btu's) average heat output. That's sufficient to effectively heat around 15 squares of any suburban home or country cottage and yet it is small enough to fit almost anywhere. Let winter do it's worst, you'll be warm and content with Nectre 15.



## Wood, the renewable fuel

### Why would you use anything else?

A major concern for all of us is the concentration of carbon dioxide in the atmosphere and the resultant rise in average global temperatures. Fuel burning is the major cause of this increase in greenhouse gas but don't confuse the burning of wood with fuels such as oil and gas.

Wood is a renewable fuel. As a tree grows, it absorbs carbon dioxide from the air and stores it in the wood as carbon. This carbon makes up about half the weight of wood. When we burn wood, carbon dioxide is released into the atmosphere again. The same amount of carbon dioxide would be released if the tree died and was left to rot on the forest floor. Our forests can therefore be perpetual source of fuel provided they are cared for and managed properly.

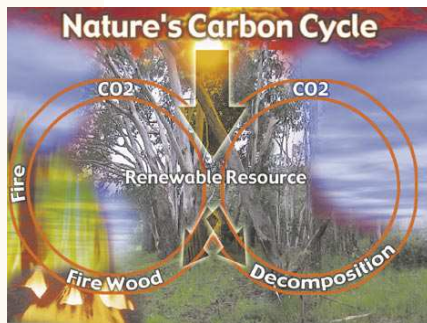

### Estimate of costs.

Heater	\$
Flue Kit	\$
Floor Protector	\$
Installation	\$
Accessories	\$
Other	\$
Total	\$

## The Baker's Oven

### A heater, classic wood oven and cooktop combined.

A unique combination of a heater and an oven, with style from a bygone era. The Nectre Baker's Oven will cook everything from crispy, fresh bread to succulent juicy roasts. The cook top takes four large saucepans or pots, and two removable rings make it ideal for wok cooking. And, while it's cooking it spreads cosy warmth through your kitchen or living areas.

An optional water jacket can be fitted to supplement your existing hot water system, too.



### Osso Bucco.

#### Italian for "Hollow Bones" and sure to fill hollow legs.

- 6 veal shanks or knuckles
- 90g butter
- 2 tablespoons oil
- Flour
- Salt, pepper
- 2 medium carrots, peeled and chopped
- 2 large onions, peeled and finely chopped
- 3 sticks celery, finely chopped
- 2 cloves garlic
- 1 cup dry red wine
- 1 1/2 cups water
- 3 beef stock cubes
- 2 x 470 g cans whole tomatoes
- 1 teaspoon basil
- 1 teaspoon thyme
- 1 bay leaf
- 2.5 cm strip lemon rind
- 1 teaspoon grated lemon rind
- 3 tablespoons chopped parsley

Coat veal shanks with flour seasoned with salt and pepper. Heat 60g butter of butter in pan with oil. Add shanks a few at a time, brown well on all sides, remove from pan. Repeat with remaining shanks. Add remaining butter to pan, add carrots, onions, celery and 1 crushed garlic clove. Saute gently until onions are golden. Remove from heat. Transfer vegetables to large ovenproof dish. Carefully pack veal shanks on top of vegetables. Drain all fat from pan in which veal was cooked. Add wine, water, crumbled stock cubes, undrained tomatoes, basil thyme, bay leaf and strip of lemon rind. Bring sauce to boil, mashing tomatoes well and stirring brown pieces from pan. Season with salt and pepper. Pour sauce over veal shanks. Cover casserole, bake in moderated oven 1.5 hours or until veal is very tender, stirring occasionally. To serve, sprinkle over combined remaining crushed garlic, chopped parsley and grated lemon rind. Serve with rice or Risotto Milanese is a traditional accompaniment.

## Nectre Features and Specifications.

- Firebricks. Increase thermal mass, stabilise temperatures and protect the firebox.
- Ash lip. All Nectres have an ash lip below the door to prevent hot coals dropping onto the floor.
- Smoke Shelf (baffle plate). Easily removed for flue cleaning and replacement.
- Minimum cleaning. Depending upon the type of wood you burn, it could be as little as once every six weeks.
- Secondary combustion. This gives more efficient burning and reduces level of emissions therefore reducing pollution.
- Bottom and rear heat shielding. Enables closer clearances to combustible materials.
- Optional fans, for all models (except the Baker's Oven). However, we recommend that a ceiling sweep fan is the best way to circulate warm air in any home – with the added bonus that it will help you stay cool in summer.
- Nectre Warranty. Nectre Slow Combustion Heaters; 10 years. Nectre Baker's Oven; 5 years.

The hearth requirements for the Nectre I5 and Mkl is a piece of cement sheet 7mm thick with 5mm tiles on top. The hearth must extend a minimum of 300mm in front of the firebox. The Mkl Pedestal may be placed directly onto a combustible floor; however a 300mm hearth must extend from the front of the pedestal. The MklII legs has the same hearth requirements as the Mkl.

The Mega requires a 12mm thick fibre cement sheet (thermal conductivity 0.41 W/m degree K) extending 650mm in front and 200mm to the sides of the firebox door opening.

An Australian standard Flue Kit to AS2918 fitted with a Flue Shield is required to obtain the specified clearances. The Mega requires a flue shield, standard drop box with full length decromesh unperforated for 120° of its circumference.

Note: Installation of the Nectre inbuilt must be in an existing masonry fireplace to comply with AS2918. Consult your dealer for details on installation requirements.

## Nectre Test Reports.

AS2918 (Clearance)

NEC I5 (AMDEL) M1563/87  
 MKI (AMDEL) M4731/88  
 MKII (AMDEL) M5512/89  
 B/OVEN (AMDEL) L1244/93  
 MEGA (AMDEL) 8AMI370

L4402/94

AS4013 (Emissions)

NEC I5 M7840/92  
 MKI M7990/92  
 MKII OAMI382  
 INBUILT L600/93  
 MEGA & BAKER'S OVEN

Cert No. E001/0793  
 Cert No. E002/0793  
 Cert No. E334/0101  
 Cert No. E10/0793  
 Exempt

*In the interest of product development, Pecan Engineering reserve the right to change product specifications without notice.*

Head Office: Pecan Engineering Pty Ltd.  
 13 Acorn Road, Dry Creek, South Australia 5094  
 Phone: (08) 8349 8332 Fax:(08) 8260 6643  
 Email: info@pecan-eng.com.au www.nectre.com



### Nectre Dimensions Free Standing

	Height (mm)	Width (mm)	Depth (mm)	Door aperture	Flue dia (mm)	Weight (kg)
<b>I5 Legs</b>	660	460	440	250 x	150	90
<b>I5 Ped</b>	730			340mm		
<b>Mkl Legs</b>	670	725	440	250 x	150	120
<b>Mkl Ped</b>	710			495mm		
<b>MklII Legs</b>	660	750	460	250 x	150	120
<b>MklII Ped</b>	725			495mm		
<b>Baker's Oven</b>	825	550	535	245 x	150	120
				345mm		
<b>Mega Legs</b>	760	760	620	265 x	150	200
<b>Mega Ped</b>	830			505mm		

### Nectre Dimensions Inbuilt

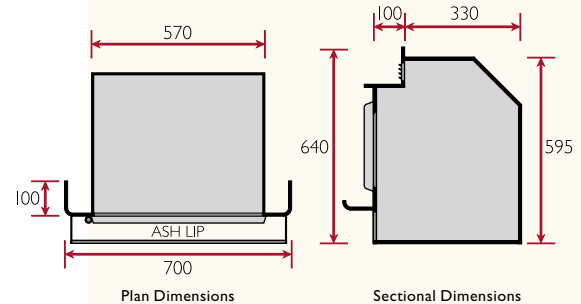

### Minimum Clearance to Combustible Materials

	I5	Mkl	MklII	B/Oven	Mega
A	200mm	150mm	75mm	125mm	350mm
B	750mm	700mm	350mm	350mm	650mm
B (with side shield)	400mm	400mm			
C (Hearth)	750mm	900mm		750mm	1100mm
D (Hearth)	900mm	850mm		960mm	1550mm

### Corner Installation

	I5	Mkl	MklII	B/Oven	Mega
E			125mm	350mm	400mm
E (with side shield)	200mm	250mm			

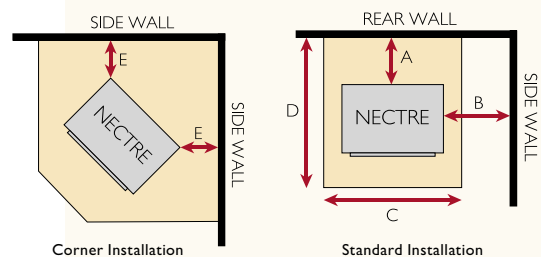

# NECTRE

SLOW COMBUSTION HEATING